

ISUZU

SPECIFICATIONS

GXD 4X2



AUSTRALIA'S TOP SELLING TRUCK BRAND SINCE 1989.

AT A GLANCE

GVM	16,500 kg
GCM	38,000 kg
Power	257 kW @ 2,000 rpm
Torque	1,422 Nm @ 1,400 rpm

ADVANCED TECHNOLOGY

Emissions: Euro V / ADR 80/03	Cross locks
Driver airbag with seatbelt pretensioner	Electro-hydraulic cab tilt
ADR 42 compliant sleeper with mattress	Coil spring cab suspension
ECE-R29 compliant cab	Front stabiliser bar
ECE-R93 compliant Front Underun Protection Device (FUPD)	Cruise control
Anti-lock Braking System (ABS)	Isri 6860 seat with integrated seatbelt



THE
one

ISUZU
RELIABILITY IS EVERYTHING

GXD Prime Mover

DRIVELINE AND CHASSIS SPECIFICATIONS

ENGINE: SITEC SERIES III 350 (ISUZU 6UZ1-TCN)

- Type:** 6 cylinder 24 valve SOHC
Displacement: 9,839 cc
Compression Ratio: 17.5:1
Bore x Stroke: 120 x 145 mm
Max power (DIN-NET): 257 kW (345 HP) @ 2,000 RPM
(JIS Gross): 265 kW (355 HP) @ 2,000 RPM
Max torque (DIN-NET): 1,422 Nm (1049 lb.ft) @ 1,400 RPM
(JIS Gross): 1,472 Nm (1,086 lb.ft) @ 1,400 RPM
Induction system: Electronically controlled variable nozzle turbocharger with air-to-air intercooler.
Fuel injection: Direct injection high pressure common rail system.
Emission control system: Cooled EGR with exhaust Diesel Oxidation Catalyst (DOC). ADR 80/03 (Euro V) compliant.

CLUTCH

- Air assisted hydraulic control. Single plate 432 mm diameter.
- Total lining area: 1,923 cm²

TRANSMISSION

ZF 9 S 1310 TO

- 9 speed with synchromesh on gears 1-8. Repeat 'H' shift pattern.
 - PTO provision at rear of transmission case.
 - Gear ratios (-1) Crawler: 9.48
- | 1st | 2nd | 3rd | 4th | 5th | 6th | 7th | 8th | Rev |
|------|------|------|------|------|------|------|------|------|
| 6.58 | 4.68 | 3.48 | 2.62 | 1.89 | 1.35 | 1.00 | 0.75 | 8.97 |

AXLES

Front: MERITOR

- FG941 reverse Elliot I-beam. 6,600 kg capacity.

Rear: MERITOR

- RS-23-161G. 10,400 kg capacity.
- Driver controlled cross lock.
- Drive ratio: 4.89:1

SUSPENSION

Front:

- Single stage alloy steel taper leaf springs.
- Double acting hydraulic shock absorbers. Stabiliser bar.

Rear:

- Hendrickson HAS230 airbag. 10,400 kg capacity at ground.
- Outboard mounted double acting shock absorbers.

BRAKES

- Meritor 'Q-Plus' dual circuit full air 'S-cam' front and rear drum brakes with auto slack adjusters and LSPV.
- ABS.
- Front drum size: 419 x 127 mm
- Rear drum size: 419 x 178 mm
- Spring park brake.
- Air controlled exhaust brake.
- Air dryer.
- Trailer brake connection at rear of cab.

STEERING

- Power assisted recirculating ball steering.
- Gear ratio: 22.4:1
- Turns lock to lock: 5.4
- Maximum angle: 45° (inside wheel) / 35° (outside wheel)

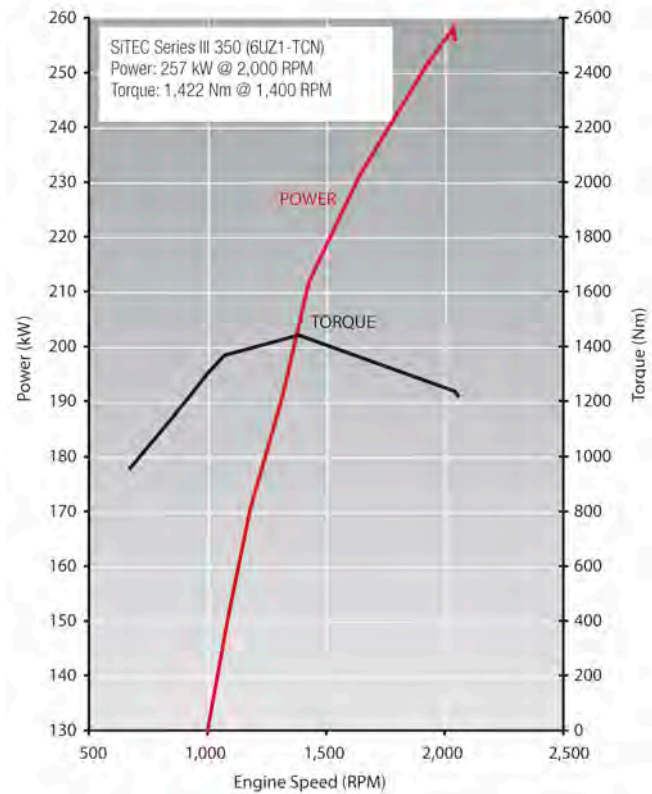

WHEELS AND TYRES

- 22.5 x 8.25 ten stud ISO standard steel wheels.
- **Steer axle:** 295/80R22.5 152/148M Michelin XZE2 Tubeless
- **Drive axle:** 11R22.5 148/145L Michelin XDE2 Tubeless
- Maximum tyre rating:
 - Steer axle: 7,100 kg
 - Drive axle: 11,600 kg
- Spare wheel rim supplied.

CHASSIS FRAME

- Cold rivetted ladder frame. HT540A high tensile weldable steel sidemembers.
- Frame dimensions:
 - Side rail (mm): 285 x 85 x 7.0
 - Rear frame width (mm): 850
- Turntable angles fitted.

FUEL TANK

- Frame mounted 400L aluminium fuel tank.
- Lockable fuel cap.

ELECTRICAL SYSTEM

- 24 volt electrical system.
- 60 amp alternator.
- 24 Volt, 5.0 kW starter motor.
- 2 x 115E41L (651 CCA) batteries connected in series.

CABIN SPECIFICATIONS AND APPOINTMENTS

CAB EXTERIOR

- All steel construction with electro-hydraulic cab tilt. High tensile steel used for cab underframe.
- Complies with ECE-R29 cab strength standard.
- Full floating cab with coil spring suspension and hydraulic shock absorbers.
- Heavy duty non slip entry steps.
- 90° opening internally reinforced front doors.
- Water spray suppression guards and front mudflaps.
- Laminated windscreen with shade band.
- Two speed windscreen wipers, with intermittent wipe mode.
- Halogen multi-reflector headlamps incorporating turn signals and front foglamps. Additional door mounted side indicator lamps.
- Combination brake, turn, reverse and marker lamps, registration plate illumination lamps. Reverse alarm.
- Roof-mounted clearance lamps.
- Heated and powered exterior main mirrors with flat glass and additional powered convex "spot" mirrors.
- Chrome grille.
- Body coloured steel air dam bumper.
- FUPD underbar - complies with ECE-R93.
- Trailer air and electrical connectors at rear of cab.

CAB INTERIOR

- Isri 6860 air suspension driver's seat with pneumatic lumbar support, height, rake and automatic weight adjustment.
- Front passenger adjustable bucket seat and front centre seat with folding seat back.
- 3-point lap sash seatbelts in all outboard seating positions. Driver seatbelt with pretensioner integrated with driver seat. Centre seat lap belts.
- ADR 42 compliant sleeper with mattress.
- Driver airbag.
- Door and roof pillar entry assist grips.
- Full interior trim, padded roof lining and vinyl floor covering. Overhead front storage compartments.
- Tilt/Telescopic adjustable steering column, soft feel urethane steering wheel.
- Central locking with remote keyless entry.
- Twin cup holders. 24V cigarette lighter. Dashboard hook.
- Front door mounted storage pockets and driver's side ashtray.
- Centre console box with storage tray.
- Front passenger glovebox.
- Fully integrated auto control air conditioning and heater/demister with 4-speed fan and outlets for windscreen, side windows, face and floor.
- Fluorescent type interior lamp with On/Door/Off switch.
- 2 DIN, two speaker radio/CD multimedia unit with 4.8" LCD touch screen and Bluetooth. Provision for SD card, USB and 3.5 mm plug inputs.
- DIN sized compartment for storage or for CB radio installation.

DRIVER CONTROLS

- Key-operated engine start/stop and steering lock. Engine idle speed control.
- Cross lock engage switch.
- **Left side combination stalk:** Windscreen wipers, washers and exhaust brake.
- **Right side combination stalk:** Turn signals, headlamps and cruise control.
- Trailer brake control valve.

INSTRUMENTATION

- Electronically driven speedometer and tachometer. Digital odometer with integrated dual tripmeter. Engine coolant temperature, fuel level and air pressure gauges.
- **Warning lamps:** Check engine, oil pressure, ABS, SRS airbag, alternator charge, service brakes, park brake, seatbelt unfastened, low air pressure, low fuel level, cab lock.
- **Indicator lamps:** Warm up system, high beam, DPD status, exhaust brake, turn signals, cruise control.
- Multi-information display. Shows service interval, instantaneous and average fuel consumption, DPD bar chart, hourmeter, voltmeter, time/day/date and includes 40-120 km/h adjustable vehicle speed warning.

OPTIONS AND GENUINE ACCESSORIES

Include the following (extra cost, request a brochure and further details from your Isuzu dealer):

- Satellite navigation - integrates with multimedia unit and includes NAVTEQ mapping.
- Up to three audio/visual reversing cameras - integrates with multimedia unit.
- Airbag compatible bullbar.
- Air deflector.



ISUZU
RELIABILITY IS EVERYTHING

WEIGHTS (kg)

Models	Ratings*		Loading Limit* (at ground)		Cab Chassis Mass #		
	GVM	GCM	Front	Rear	Front	Rear	Total
GXD Prime Mover	16,500	38,000	6,600	10,400	3,950	1,570	5,520

*Vehicle ratings and front/rear weight limits are subject to government regulatory requirements and weight distribution analysis. 16,500 kg is maximum optional GVM rating. Consult your Isuzu dealer to select the correct vehicle for your specific application. # Cab chassis only as supplied and including 10 litres of fuel.

DIMENSIONS (mm)

Models	WB	OAL	FOH	ROH	EA	CE	RT	ORT	CH	Turn Circle (m)			KERB TO KERB
										FFA (unladen)	RFA (unladen)	RFH (unladen)	
GXD Prime Mover	3,480	5,795	1,480	935	2,800	3,855	1,840	2,445	2,980	925	1,035	1,040	12.1

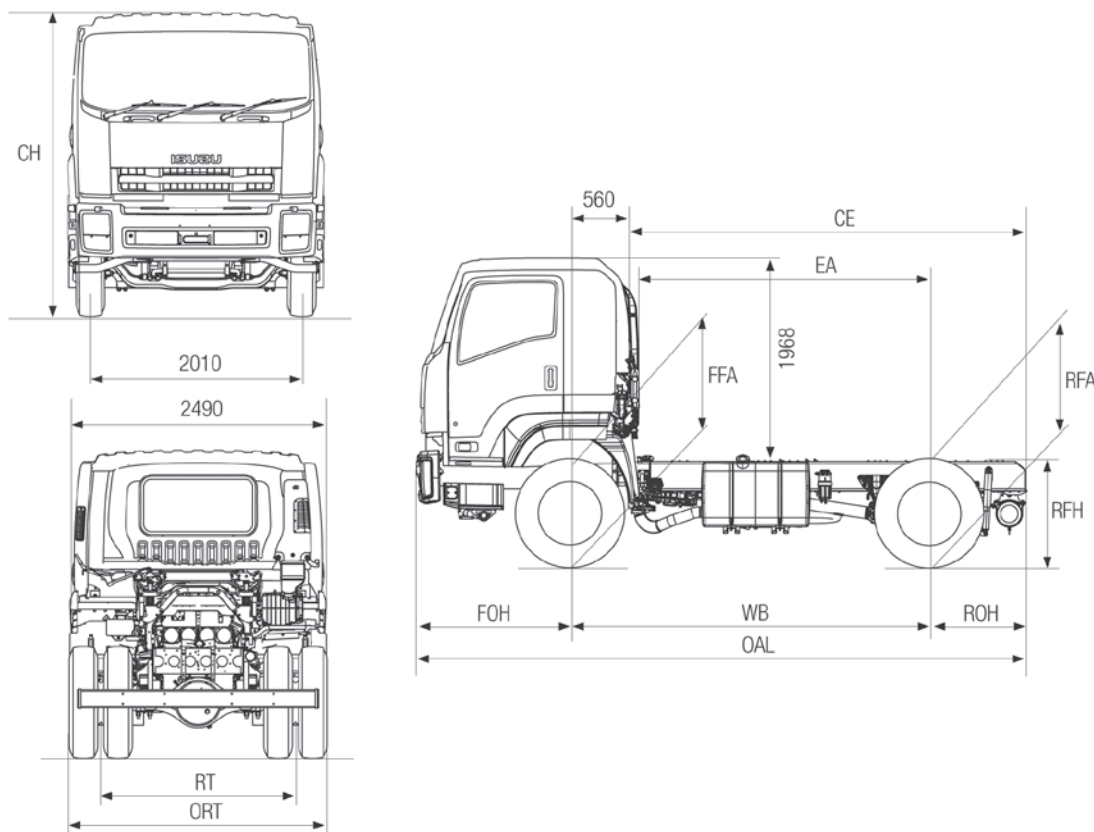

PERFORMANCE (calculated - typical paved road)

		Geared Speed* (top gear at peak power engine RPM)	Low Speed Gradeability (lowest forward gear assuming no wheel slip)	Engine Speed (top gear at 100km/h)
GXD Prime Mover	At 38,000 kg GVM	106 km/h @ 2,000 RPM	30%	1,895 RPM

* Maximum speed achievable depends on vehicle frontal area as well as other factors. Consult your Isuzu dealer for more detailed information. Vehicle is speed limited to 100 km/h.

ISUZU WARRANTIES

STANDARD ¹		
New Vehicle	3 years • 250,000km • 4,000 hours	
Cab Perforation Corrosion	3 years • unlimited km's	
EXTENDED ²		
4 years, 350,000km	5 years • 400,000km	6 years • 450,000km
Isuzu Assist - 24 hour roadside assistance (3 years, unlimited km's)*		

ORDER CODES

Model	Code
GXD Prime Mover	FH-GXDJJ-A11

¹ Subject to the conditions outlined in the IAL New Vehicle Warranty, the Isuzu GXD model carries a standard factory warranty which covers the owner: (i) for the entire vehicle, for the first 36 months or 250,000 km or 4,000 hrs (whichever comes first), (ii) against cab perforation corrosion, for 36 months and unlimited kilometres. ² Extended Warranty as illustrated is available by purchase to cover the owner against the failure of original components, but may exclude some components and expendable items such as oil, filters, etc. Please consult with your Isuzu Dealer for full details obtained from a dedicated brochure available to customers. *Valid for three years from the date of new vehicle purchases.

ISUZU AUSTRALIA LIMITED ABN 97 006 962 572 ("IAL"). The information in this brochure was correct at time of printing, but all measurements, specifications and equipment are subject to change without notice. Some equipment may have been changed and/or is available at extra cost. IAL may make changes at any time without notice, in prices, colours, materials, equipment and models. IAL makes all reasonable attempts to ensure the availability of all vehicles and equipment. The information in this brochure is general in nature. Your Isuzu dealer can confirm all measurements, specifications and vehicle / equipment availability upon request.

TIC: Isuzu is a member of the Truck Industry Council - Safer Greener Essential.

April 2011.ARK0557



ISUZU
RELIABILITY IS EVERYTHING