

# ISUZU

## SPECIFICATIONS

### FSR 700 | 850

### FSD 700 | 850



FSR 700

AUSTRALIA'S TOP SELLING TRUCK BRAND SINCE 1989.

#### AT A GLANCE

GVM	12,000 / 14,000 kg*
GCM	18,000 / 20,000 kg (except auto model) 15,000 kg* (auto model)
Power	176 kW @ 2,400 rpm
Torque	706 Nm @ 1,450 rpm

#### UPGRADE OPTIONS

**Premium Pack:** Automated Manual Transmission, AMT), Auto control for air conditioning, Chrome grille

\* Auto model rating dependent on application

#### ADVANCED TECHNOLOGY

Emissions: Euro V / ADR 80/03	Hill Start Aid (HSA) - except auto model
Meets EEV emissions standard	Electric mirrors
Driver airbag with seatbelt pretensioner	Front stabiliser bar
ADR42 compliant sleeper	Cruise control
ECE-R29 compliant cab	Isri 6860 seat with integrated seatbelt
Anti-lock Braking System (ABS)	Electronically controlled 4-bag air rear suspension (FSD model)
Anti Skid Regulator (ASR)	



THE  
**one**

**ISUZU**  
RELIABILITY IS EVERYTHING

### DRIVELINE AND CHASSIS SPECIFICATIONS

#### ENGINE: SITEC SERIES III 235 (ISUZU 6HK1-TCN)

- Type:** 6 cylinder 24 valve SOHC  
**Displacement:** 7,790 cc  
**Compression Ratio:** 17.5:1  
**Bore x Stroke:** 115 mm x 125 mm  
**Max power (DIN-NET):** 176 kW (236 HP) @ 2,400 RPM  
**(JIS Gross):** 182 kW (244 HP) @ 2,400 RPM  
**Max torque (DIN-NET):** 706 Nm (521 lb.ft) @ 1,450 RPM  
**(JIS Gross):** 731 Nm (539 lb.ft) @ 1,450 RPM  
**Induction system:** Electronically controlled variable nozzle turbocharger with air-to-air intercooler.  
**Fuel injection:** Direct injection high pressure common rail system.  
**Emission control system:** Cooled EGR with exhaust Diesel Particulate Diffuser (DPD). ADR 80/03 (Euro V) compliant. EEV compliant.

#### CLUTCH (MANUAL/AMT TRANSMISSION MODEL)

- Standard model:**
- Air assisted hydraulic control. Single plate 381 mm diameter.
  - Total lining area: 1,363 cm<sup>2</sup>
- Premium Pack:**
- Fully automated hydraulically controlled wet clutch and fluid coupling with lock up.

#### TRANSMISSION

- ISUZU MZW-6P** (except auto model)
- Synchromesh on gears 2-6. Triple cone synchromesh on 2nd and 3rd gears. Integral oil pump provides full pressure lubrication.
  - PTO provision on LHS of transmission case. PTO drive from mainshaft gear.
  - Gear ratios (:1)
- | 1st   | 2nd   | 3rd   | 4th   | 5th   | 6th   | Rev   |
|-------|-------|-------|-------|-------|-------|-------|
| 6.615 | 4.095 | 2.358 | 1.531 | 1.000 | 0.722 | 6.615 |

- Standard model:**
- 6 speed manual with air assisted shift.
- Premium Pack:**
- 6 speed Automated Manual Transmission (AMT) with both fully automatic and clutchless manual operation modes.

- ALLISON LCT2500** (auto model)
- 5 speed automatic. 4th generation electronic controls with adaptive shift.
  - LHS and RHS PTO openings on transmission case. Torque convertor turbine driven PTO drive gear.
  - Gear ratios (:1)
- | 1st  | 2nd  | 3rd  | 4th  | 5th  | Rev  |
|------|------|------|------|------|------|
| 3.51 | 1.90 | 1.44 | 1.00 | 0.74 | 5.09 |

#### AXLES

- Front:** Isuzu F050
- Reverse Elliot I-beam. 5,000 kg capacity.
- Rear:** Isuzu R090
- Full floating Banjo type. 9,000 kg capacity.
  - Drive ratio: 4.875:1

#### SUSPENSION

- Front:**
- Single stage alloy steel taper leaf springs.
  - Double acting hydraulic shock absorbers. Stabiliser bar.
- Rear (FSR 700/850):**
- Multi leaf main spring, multi leaf helper spring.
- Rear (FSD 700/850):**
- Isuzu 4-bag electronically controlled air suspension system.
  - Double acting hydraulic shock absorbers. Stabiliser bar.

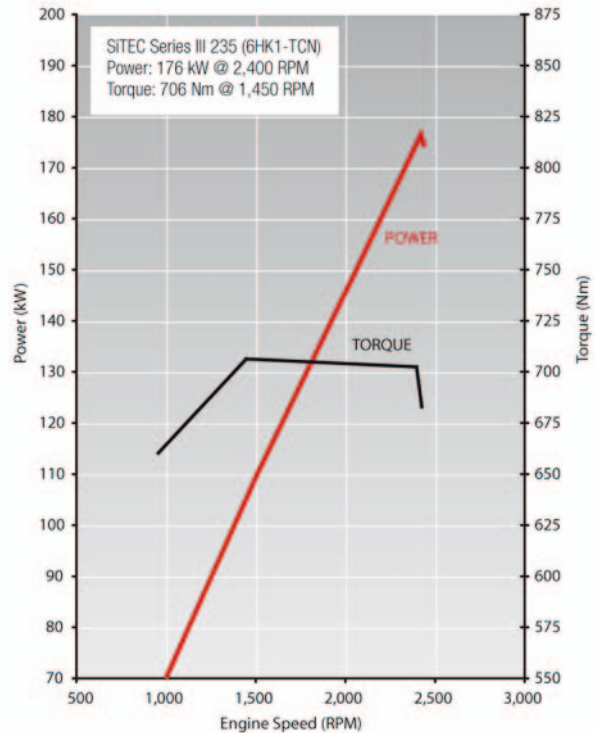

#### BRAKES

- Dual circuit air over hydraulic front and rear drum brakes.
- ABS.
- ASR traction control.
- Hill Start Aid (HSA) - except auto model.
- Front drum size: 370 x 150 mm
- Rear drum size: 370 x 150 mm
- Spring park brake.
- Air controlled exhaust brake.
- Air dryer.

#### STEERING

- Power assisted recirculating ball steering.
- Gear ratio: 16:1 - 18.8:1
- Turns lock to lock: 4.1
- Maximum angle: 44° (inside wheel) / 34° (outside wheel)

#### WHEELS AND TYRES

- 19.5 x 6.75 eight stud steel wheels.
- 265/70R19.5 140/138M Michelin XZE2 Tubeless.
- Maximum tyre rating:
  - Steer axle: 5,000 kg
  - Drive axle: 9,440 kg
- Spare wheel and tyre assembly with winch type carrier.

#### CHASSIS FRAME

- Cold rivetted ladder frame with parallel side rails. HT540A high tensile weldable steel sidemembers.
- Frame dimensions:
  - Side rail (mm): 225 x 70 x 6.0
  - Rear frame width (mm): 840

## FUEL TANK

- Frame mounted 200L steel fuel tank.
- Lockable fuel cap.

## ELECTRICAL SYSTEM

- 24 volt electrical system.
- **Manual model:** 60 amp alternator. **Auto model:** 90 amp alternator.
- 24 Volt, 4.5 kW starter motor.
- 2 x 115E41L (651 CCA) batteries connected in series.

## CABIN SPECIFICATIONS AND APPOINTMENTS

### CAB EXTERIOR

- All steel construction. High tensile steel used for cab underframe. Manual cab tilt to 45° with torsion bar assistance.
- Complies with ECE-R29 cab strength standard.
- Liquid filled front and rear cab mounts.
- Heavy duty non slip entry steps.
- 90° opening internally reinforced front doors.
- Water spray suppression guards and front mudflaps.
- Laminated windscreen with shade band.
- Two speed windscreen wipers, with intermittent wipe mode.
- Halogen multi-reflector headlamps incorporating turn signals. Additional door mounted side indicator lamps.
- Combination brake, turn, reverse and marker lamps, registration plate illumination lamps. Extended wiring harness. Reverse alarm.
- Roof-mounted clearance lamps.
- Heated and powered exterior main mirrors with flat glass and additional powered convex "spot" mirrors.
- **Except Premium Pack:** Body coloured grille. **Premium Pack:** Chrome grille.
- Body coloured steel air dam bumper with front foglamps.

### CAB INTERIOR

- Isri 6860 air suspension driver's seat with pneumatic lumbar support, height, rake and automatic weight adjustment.
- Front passenger adjustable bucket seat and front centre seat with folding seat back.
- 3-point lap sash seatbelts in all outboard seating positions. Driver seatbelt with pretensioner integrated with driver seat. Centre seat lap belts.
- ADR42 compliant sleeper.
- Driver airbag.
- **Premium Pack:** Driver's footrest.
- Door and roof pillar entry assist grips.
- Full interior trim, padded roof lining and vinyl floor covering. Driver and passenger windscreen header storage shelf.
- Tilt/Telescopic adjustable steering column, soft feel urethane steering wheel.
- Electric windows.
- Central locking with remote keyless entry and immobiliser.
- Twin cup holders. 24V cigarette lighter. Dashboard hook.
- Front door mounted storage pockets and driver's side ashtray.
- Centre console box with storage tray. Fold down storage tray behind centre seat backrest.
- Front passenger glovebox.
- Fully integrated air conditioning and heater/demister with 4-speed fan and outlets for windscreen, side windows, face and floor. **Except Premium Pack:** Manual control. **Premium Pack:** Auto control.
- Fluorescent type interior lamp with On/Door/Off switch.
- 2 DIN, two speaker radio/CD multimedia unit with 4.8" LCD touch screen and Bluetooth. Provision for SD card, USB and 3.5 mm plug inputs.
- DIN sized compartment for storage or for CB radio installation.

### DRIVER CONTROLS

- Key-operated engine start/stop and steering lock. Engine idle speed control.
- HSA slow/fast engagement control and on/off switch (except auto model).
- ASR on/off.
- DPD regeneration.
- Hand held pendant for rear suspension raise and lower.
- **Premium Pack:** AMT slow/fast gear engagement control, 1st gear start and normal/economy gear selection modes.
- T-bar gear selection control (auto model).
- **Left side combination stalk:** Windscreen wipers, washers and exhaust brake.
- **Right side combination stalk:** Turn signals, headlamps and cruise control.

### INSTRUMENTATION

- Electronically driven speedometer and tachometer. Digital odometer with integrated dual tripmeter. Engine coolant temperature, fuel level and air pressure gauges.
- **Warning lamps:** Check engine, oil pressure, ABS, SRS airbag, alternator charge, service brakes, park brake, seatbelt unfastened, low air pressure, air suspension failure, low fuel level, cab lock. **Premium Pack:** Check AMT.
- **Indicator lamps:** HSA (except auto model), warm up system, high beam, ASR, DPD status, exhaust brake, turn signals, cruise control. **Premium Pack:** Econo-mode, 1st gear start.
- **Premium Pack:** Gear selection display.
- Multi-information display. Shows service interval, instantaneous and average fuel consumption, DPD bar chart, hourmeter, voltmeter, time/day/date and includes 40-120 km/h adjustable vehicle speed warning.

### OPTIONS AND GENUINE ACCESSORIES

Include the following (extra cost, request a brochure and further details from your Isuzu dealer):

- Satellite navigation - integrates with multimedia unit and includes NAVTEQ mapping.
- Up to three audio/visual reversing cameras - integrates with multimedia unit.
- Airbag compatible bullbar.
- Air deflector.



**ISUZU**  
RELIABILITY IS EVERYTHING

### WEIGHTS (kg)

Models	Ratings*		Loading Limit* (at ground)		Cab Chassis Mass #		
	GVM	GCM	Front	Rear	Front	Rear	Total
FSR 700 / 850 Auto	12,000 / 14,000**	15,000**	5,000	9,000	2,370	1,405	3,775
FSR 700 / 850 Long	12,000 / 14,000	18,000 / 20,000	5,000	9,000	2,450	1,450	3,900
FSR 700 / 850 Long Premium	12,000 / 14,000	18,000 / 20,000	5,000	9,000	2,465	1,455	3,920
FSR 700 / 850 X-Long Premium	12,000 / 14,000	18,000 / 20,000	5,000	9,000	2,540	1,530	4,070
FSD 700 / 850 Long	12,000 / 14,000	18,000 / 20,000	5,000	9,000	2,455	1,510	3,965
FSD 700 / 850 Long Premium	12,000 / 14,000	18,000 / 20,000	5,000	9,000	2,495	1,530	4,025

\* Vehicle ratings and front/rear weight limits are subject to government regulatory requirements and weight distribution analysis. Consult your Isuzu dealer to select the correct vehicle for your specific application.

\*\* Street sweeper only. Refuse application GVM and GCM limited to 12,000 kg. # Cab chassis only as supplied and including 10 litres of fuel.

### DIMENSIONS (mm)

Models	WB	OAL	FOH	ROH	EA	CE	RT	ORT	CH	Turn Circle (m)			
										FFA (unladen)	RFA (unladen)	RFH (unladen)	KERB TO KERB
FSR 700 / 850 Auto	3,790	6,555	1,170	1,595	2,770	4,490	1,660	2,215	2,665	745	885	940	13.6
FSR 700 / 850 Long	5,560	9,155	1,170	2,425	4,575	7,090	1,660	2,215	2,665	745	885	940	19.9
FSR 700 / 850 X-Long	6,560	10,705	1,170	2,975	5,575	8,640	1,660	2,215	2,665	750	880	935	23.5
FSD 700 / 850 Long	5,560	9,155	1,170	2,425	4,575	7,090	1,660	2,215	2,590	745	790	790	19.9

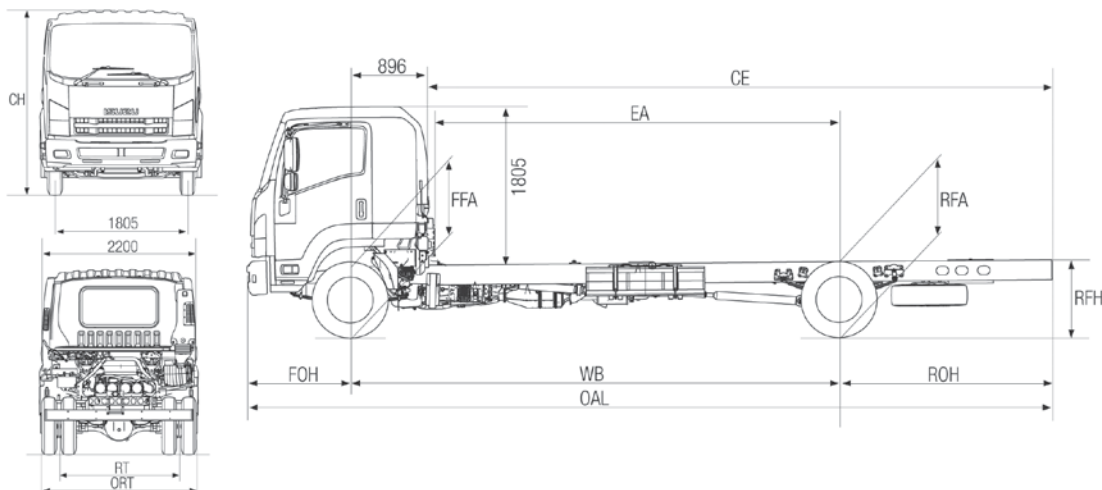

### PERFORMANCE (calculated - typical paved road)

		Geared Speed* (top gear at peak power engine RPM)	Low Speed Gradeability (lowest forward gear assuming no wheel slip)	Engine Speed (top gear at 100km/h)
FSR / FSD 700	At 12,000 kg GVM	108 km/h @ 2,400 RPM	41%	2,215 RPM
FSR 700 Auto	At 12,000 kg GVM	106 km/h @ 2,400 RPM	34%	2,275 RPM
FSR / FSD 850	At 14,000 kg GVM	108 km/h @ 2,400 RPM	35%	2,215 RPM
FSR 850 Auto	At 14,000 kg GVM	106 km/h @ 2,400 RPM	29%	2,275 RPM

\* Maximum speed achievable depends on vehicle frontal area as well as other factors. Consult your Isuzu dealer for more detailed information. FSR/FSD 850-S models speed limited to 100km/h.

### ISUZU WARRANTIES

STANDARD <sup>1</sup>		
New Vehicle	3 years • 150,000km • 2,500 hours	
Cab Perforation Corrosion	3 years • unlimited km's	
EXTENDED <sup>2</sup>		
4 years, 250,000km	5 years • 300,000km	6 years • 350,000km
Isuzu Assist - 24 hour roadside assistance (3 years, unlimited km's)*		

### ORDER CODES

Model	Code	Model	Code
FSR 700 / 850 Auto	FH-FSRCF-K11	FSR 700 / 850 X-Long Premium	FH-FSRDF-J11
FSR 700 / 850 Long	FH-FSRCF-D11	FSD 700 / 850 Long	FH-FSDCF-D11
FSR 700 / 850 Long Premium	FH-FSRDF-Z11	FSD 700 / 850 long premium	FH-FSDDF-Z11

<sup>1</sup> Subject to the conditions outlined in the IAL New Vehicle Warranty, the Isuzu FSR and FSD models carry a standard factory warranty which covers the owner: (i) for the entire vehicle, for the first 36 months or 150,000 km or 2,500 hrs (whichever comes first), (ii) against cab perforation corrosion, for 36 months and unlimited kilometres. <sup>2</sup> Extended Warranty as illustrated is available by purchase to cover the owner against the failure of original components, but may exclude some components and expendable items such as oil, filters, etc. Please consult with your Isuzu Dealer for full details obtained from a dedicated brochure available to customers. \*Valid for three years from the date of new vehicle purchases.

ISUZU AUSTRALIA LIMITED ABN 97 006 962 572 ("IAL"). The information in this brochure was correct at time of printing, but all measurements, specifications and equipment are subject to change without notice. Some equipment may have been changed and/or is available at extra cost. IAL may make changes at any time without notice, in prices, colours, materials, equipment and models. IAL makes all reasonable attempts to ensure the availability of all vehicles and equipment. The information in this brochure is general in nature. Your Isuzu dealer can confirm all measurements, specifications and vehicle / equipment availability upon request.

TIC: Isuzu is a member of the Truck Industry Council - Safer Greener Essential.

June 2011. ARK0561



**ISUZU**  
RELIABILITY IS EVERYTHING